

Installation Manual

C-2203
ARNOTT REAR COIL SPRING CONVERSION KIT
FOR 1998-2004
LAND ROVER DISCOVERY II



Congratulations on your purchase of an Arnett® air suspension product. We at Arnett Incorporated are proud to offer a high quality product at the industry's most competitive pricing. Thank you for your confidence in us and our product.

Proper installation is essential to experience and appreciate the benefits of this system. Please take a moment to review these installation instructions before you begin to install these components on your vehicle. The removal and installation of air suspension products should only be performed by a fully qualified, ASE Certified, professional.

It is equally important to be aware of all necessary safety measures while installing your new Air Suspension System. This includes proper lifting and immobilizing of the vehicle and isolation of any stored energy to prevent personal injury or property damage.

"Engineered to Ride, Built to Last®"



WARNING: *The air suspension system is under pressure (up to 10 bar, or 150 lbf/in). Verify pressure has been relieved and disconnect power to the air suspension system prior to disassembly. Do not allow dirt or grease to enter the system. Always wear standard hand, ear, and eye protection when servicing the air suspension system.*

Arnett® is committed to the quality of its products. If you have a question or problem with any Arnett product, please contact Arnett by calling [800-251-8993](tel:800-251-8993) during normal business hours or email techassistance@arnottinc.com.

GENERAL INFORMATION:

Reading this manual signifies your agreement to the terms of the general release, waiver of liability, and hold harmless agreement, the full text of which is available at www.arnottinc.com.

- Not to be stored below 5°F (-15°C) or above 122°F (50°C).
- Avoid damage to air lines and cables.
- Removal and installation is only to be performed by fully qualified personnel.
- Use car manufacturer's diagnostic software.

CAUTION: *Damage to the vehicle and air suspension system can be incurred if work is carried out in a manner other than specified in the instructions or in a different sequence.*



To avoid the possibility of short circuits while working with electric components consult your owner's manual on how to disconnect your battery.



Consult your vehicle owner's manual, service manual, or car dealer for the correct jacking points on your vehicle and for additional care, safety and maintenance instructions. Under no circumstances should any work be completed underneath the vehicle if it is not adequately supported, as serious injuries and death can occur.

REMOVAL

1. Lift vehicle and remove both rear wheels.
2. Disconnect the air fitting from the top of the air spring. Removing the air fitting will depressurize the air spring.
3. Seal off hose to prevent dirt or grease from entering system.
4. Remove the two clips securing the top of the air spring to chassis.
5. Collapse the air spring.
6. Rotate the air spring to unlock it from the axle, and remove the old air spring from the vehicle.

INSTALLATION



Tighten all nuts and bolts to manufacturer's specifications during the installation process.

NOTE:

Tie the wires and air hose back away from any hot or moving parts. Do not cut the wires. Leave the system whole in case you ever want to reinstall air suspension on the vehicle.

1. Locate the two holes for the spring seat retaining bolts. Run a 10mm x 1.50 tap through these holes to ease installation of retaining bolts.
2. Install the lower spring seat onto axle.
3. Using a floor jack, raise the rear axle to release tension from the shock absorber. Remove lower shock bolt. Release ABS sensor lead from bracket.
4. Install the upper spring isolator to top of the spring. **NOTE:** *The spring has the tighter coils at the top.*
5. Lower axle until the spring can be installed in place.
6. Repeat for opposite side.

DISARMING THE AIR SUSPENSION SYSTEM

1. Locate the vehicles air suspension control module. unplug the wiring harness from the control module to eliminate any dash warning lights.
2. Reprogram slabs computer to coil springs using autologic or test book diagnostic system. (This will disable the air suspension system.)

REMOVAL DIAGRAM

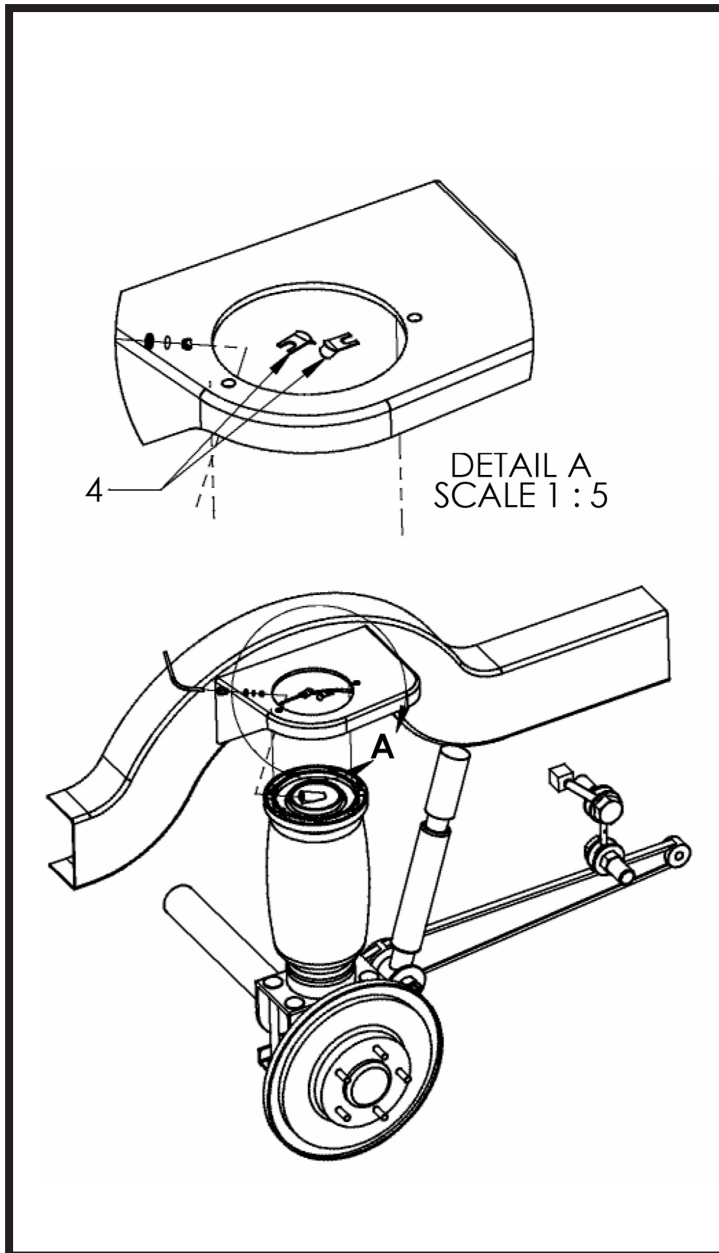

INSTALLATION DIAGRAM

