

Congratulations on your purchase of an Arnett® air suspension product. We at Arnett Incorporated are proud to offer a high quality product at the industry's most competitive pricing. Thank you for your confidence in us and our product.

Proper installation is essential to experience and appreciate the benefits of this system. Please take a moment to review these installation instructions before you begin to install these components on your vehicle. The removal and installation of air suspension products should only be performed by a fully qualified, ASE Certified, professional.

It is equally important to be aware of all necessary safety measures while installing your new Air Suspension System. This includes proper lifting and immobilizing of the vehicle and isolation of any stored energy to prevent personal injury or property damage.

"Engineered to Ride, Built to Last®"



WARNING: *The air suspension system is under pressure (up to 10 bar, or 150 lbf/in). Verify pressure has been relieved and disconnect power to the air suspension system prior to disassembly. Do not allow dirt or grease to enter the system. Always wear standard hand, ear, and eye protection when servicing the air suspension system.*

Arnett® is committed to the quality of its products. If you have a question or problem with any Arnett product, please contact Arnett by calling [800-251-8993](tel:800-251-8993) during normal business hours or email techassistance@arnottinc.com.

GENERAL INFORMATION:

Reading this manual signifies your agreement to the terms of the general release, waiver of liability, and hold harmless agreement, the full text of which is available at www.arnottinc.com.

- Not to be stored below 5°F (-15°C) or above 122°F (50°C).
- Avoid damage to air lines and cables.
- Removal and installation is only to be performed by fully qualified personnel.
- Use car manufacturer's diagnostic software.

CAUTION: Damage to the vehicle and air suspension system can be incurred if work is carried out in a manner other than specified in the instructions or in a different sequence.



To avoid the possibility of short circuits while working with electric components consult your owner's manual on how to disconnect your battery.



Consult your vehicle owner's manual, service manual, or car dealer for the correct jacking points on your vehicle and for additional care, safety and maintenance instructions. Under no circumstances should any work be completed underneath the vehicle if it is not adequately supported, as serious injuries and death can occur.

AIR SUSPENSION COMPRESSOR REMOVAL

1. Turn air suspension switch to the off position. (Switch is located on the right side of the trunk.)
2. Locate compressor on the right side of the vehicle, behind the front bumper.
3. To remove the front bumper cover, start with removing front side marker/cornering lamps.
4. Remove the radiator upper sight shield (FIGURE A).

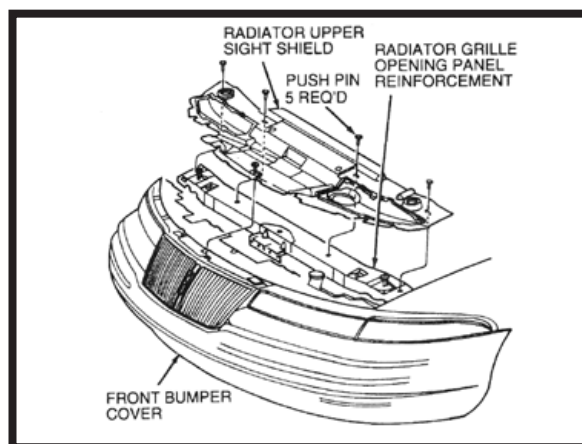

FIGURE A

5. Remove the radiator grille opening panel moulding across the top of the headlamps and front bumper cover. (FIGURE B for steps 5-13)
6. Remove six (6) screws (three (3) each side) attaching front bumper cover to right and left front fender splash shields at the front fender wheel opening.
7. Remove four (4) screws (two (2) each side) attaching bottom of front bumper cover to right and left front fender splash shields.
8. Remove four (4) nuts (two (2) each side) through front side marker/cornering lamp openings attaching front bumper cover to front fenders.
9. Remove two (2) bolts attaching radiator grille opening panel brackets to radiator grille opening reinforcement.
10. Remove one screw attaching bottom center of front bumper cover to "z" brace.
11. Remove four push pins attaching bottom of front bumper cover to radiator grille opening panel reinforcement.
12. Carefully pull front bumper cover and radiator grille away from vehicle.
13. Remove one rivet and "z" brace from bottom of radiator grille opening panel reinforcement.

Item	Part Number	Description
1	17D957	Front Bumper Cover
2	17E898	Front Valance Panel Bracket
3	17757	Front Bumper
4	8A284	Radiator Grille Opening Panel Reinforcement
5A	N621907-S55	Nut (4 Req'd)
6	N804765-S	Nut Insert (2 Req'd)
7	16102 RH 16103 LH	Front Fender Splash Shield

Item	Part Number	Description
8B	N56913-S55	Screw (10 Req'd)
9	N803678-S	Push Pin (4 Req'd)
10	N802781-S	Push Pin
11	N803043-S	Rivet (2 Req'd)
12	17A385	Front License Plate Mounting Bracket
13C	N606676-S55	Bolt (2 Req'd)
A		Tighten to 5.8-8.2 N-m (52-72 Lb-in)

Item	Part Number	Description
B		Tighten to 1.3-1.7 N-m (12-15 Lb-in)
C		Tighten to 5.5-7.5 N-m (49-68 Lb-in)

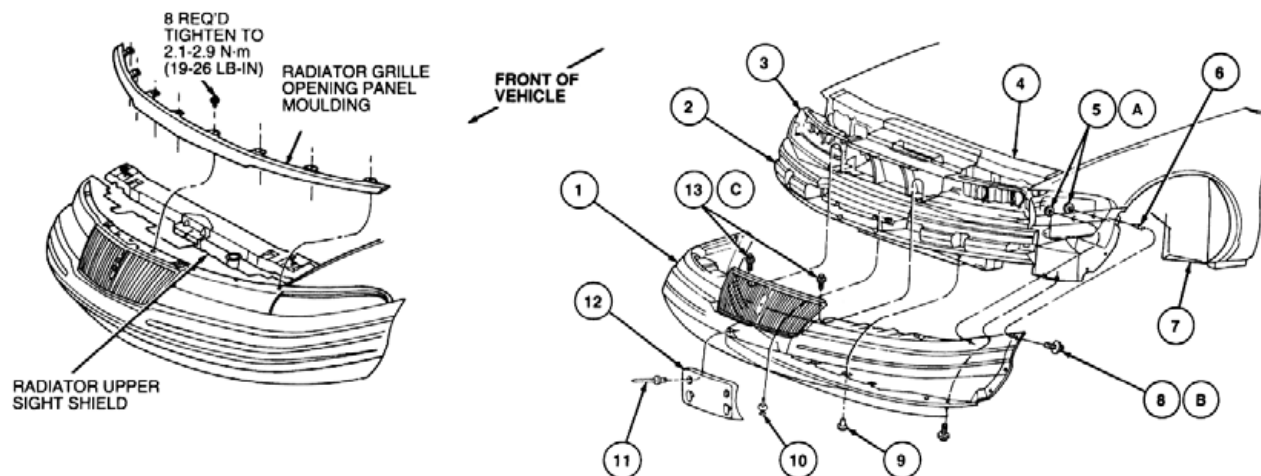

FIGURE B

14. Remove vapor canister retaining bolt. Partially lower fuel vapor canister and disconnect fuel vapor hose and fuel vapor canister purge regulator valve from fuel vapor canister (FIGURE C)

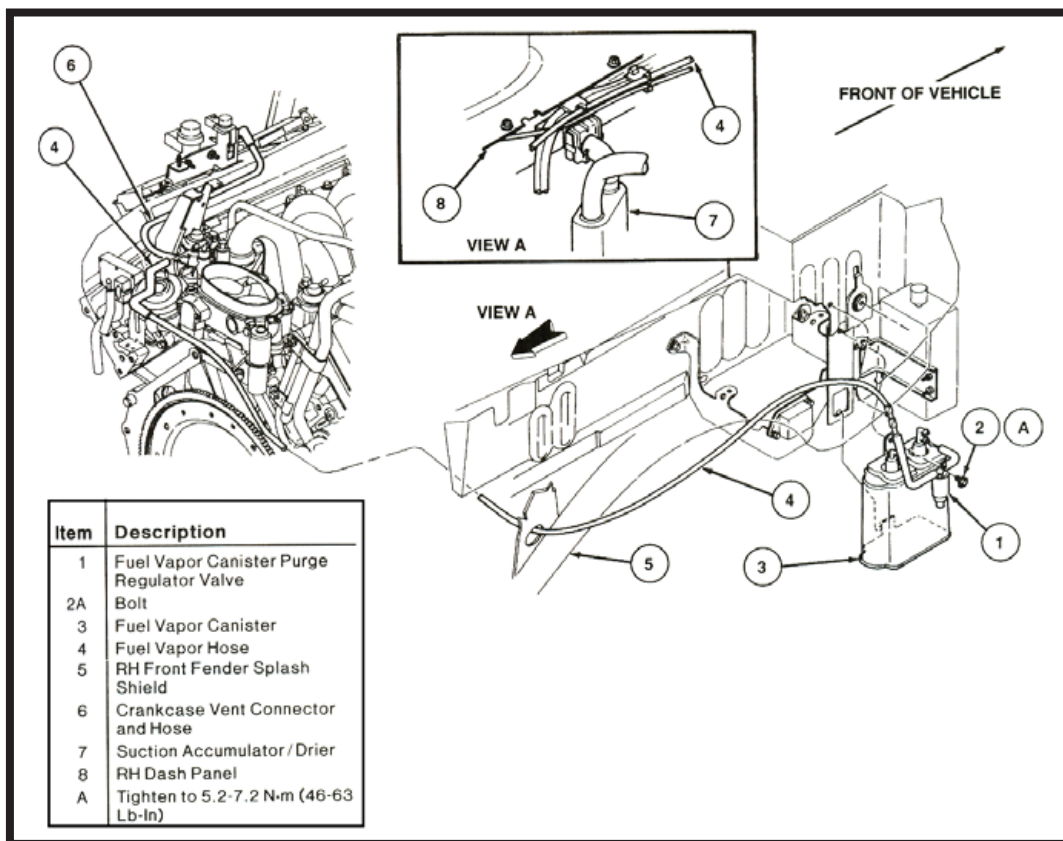

FIGURE C

15. Disconnect electrical connector for compressor motor (located on front face of compressor bracket). (FIGURES D, E FOR STEPS 15-24)
17. Disconnect solid-state relay connector (located on outboard face of compressor bracket).

NOTE: TO RELEASE AIR TUBE(S) YOU MUST PRESS DOWN ON TWO SIDES OF THE QUICK RELEASE FITTING AND PULL OUT AIR TUBE(S).

18. Disconnect four (4) air lines from compressor air dryer.
19. Disconnect wiring harness and front left air line clip from rear face of compressor.
20. Remove two (2) lower screws retaining bracket to body.
21. Remove upper screw retaining top of compressor bracket to body.
22. Remove air compressor.
23. Detach air intake hose from top of compressor head.

24. Remove screws attaching noise attenuator from front face of compressor bracket and remove attenuator.

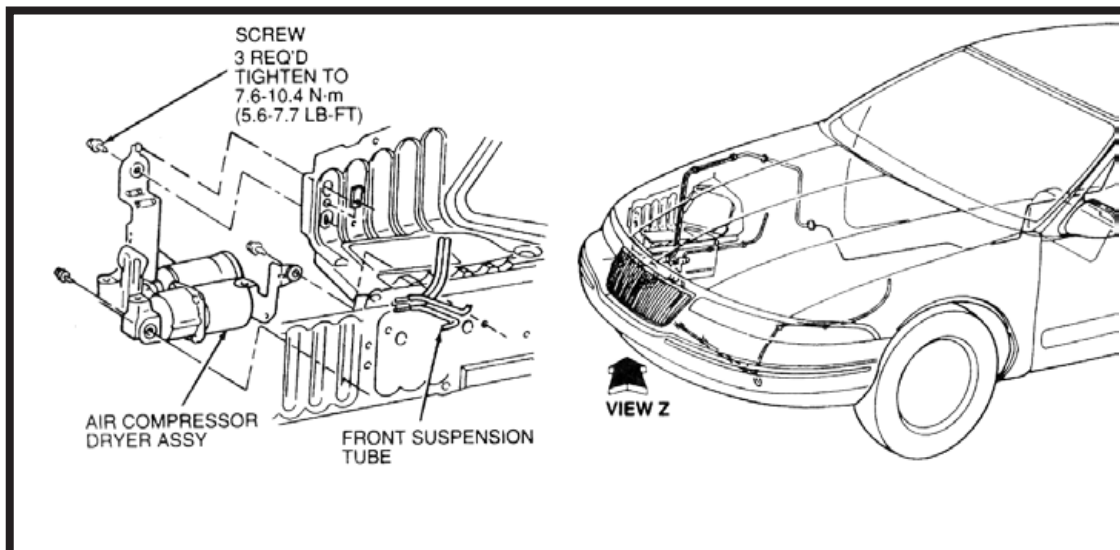

FIGURE D

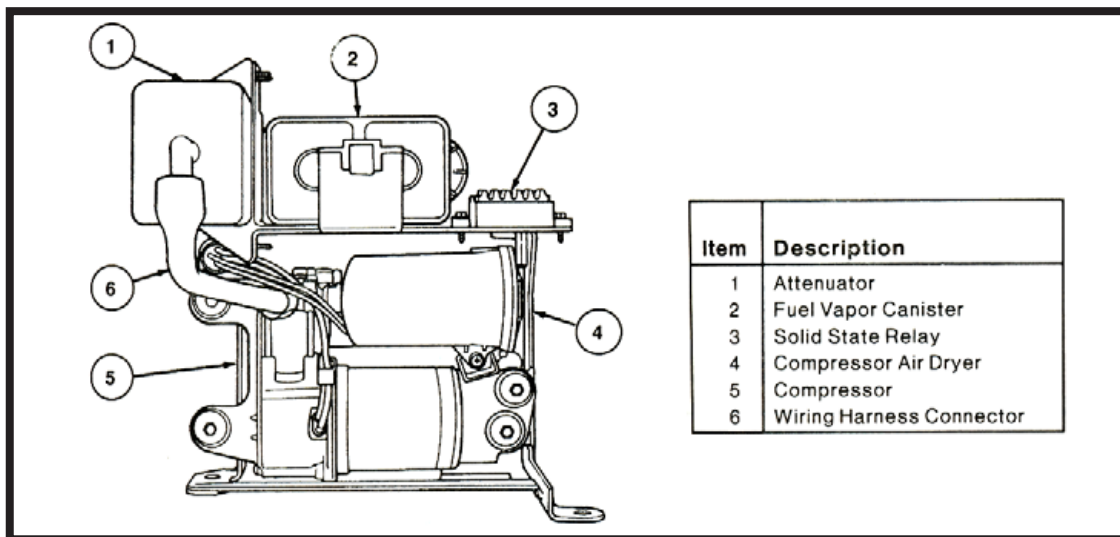

FIGURE E

25. Removal complete.

AIR SUSPENSION COMPRESSOR INSTALLATION



Tighten all nuts and bolts to manufacturer's specifications during the installation process.



When installing the air tube, push tubing into fitting until it bottoms out.

1. Installation is in the reverse order of air compressor removal.



WARNING



CRACKED AIR SPRINGS MUST BE CHANGED TO VALIDATE THE WARRANTY ON THE COMPRESSOR

PLEASE READ ADDITIONAL WARRANTY INFORMATION ON THE BACK OF YOUR INVOICE



PROPER PROCEDURE FOR ASSESSING YOUR AIR SPRINGS CONDITION:

1. TURN OFF AIR SUSPENSION SWITCH IF EQUIPPED.
2. REFER TO OWNER'S MANUAL FOR PROPER LIFTING TECHNIQUES AND JACKING POINTS.
3. RAISE THE VEHICLE.
4. INSPECT AIR SPRINGS FOR ANY TYPE OF CRACKS OR EXCESSIVE WEAR. CRACKS IN AIR SPRINGS ARE EVIDENT IF THEY ARE LEAKING. THIS WILL CAUSE THE COMPRESSOR TO OVERHEAT FROM CONTINUOUS OPERATION.

Arnott[®] is committed to the quality of its products. If you have a question or problem with any Arnott product, please contact Arnott by calling [800-251-8993](tel:800-251-8993) during normal business hours or email techassistance@arnottinc.com